

Highlights:

- Results in 5 minutes
- Any combination of strips in convenient comb format
- Up to 8 tests - in any combination - from one Common Extraction™:
 - Cry1A (MON810)
 - Cry9C (StarLink®)
 - CP4 EPSPS (Roundup Ready®)
 - Cry3Bb (YieldGard® Rootworm)
 - Cry1F (Herculex™ I)
 - PAT/pat (LibertyLink®)
 - Cry34 (Herculex RW)
 - mCry3A (Agrisure RW)

Contents of Kit:

- 5 to 8 QuickStix Strips per comb, packaged 5 combs per foil bag
- Sample cups and disposable transfer pipettes

Items Not Provided:

- Bunn grinder or equivalent
- Graduated cylinder
- Tap water
- QuickScan System

For sampling scenarios at different screening or confidence levels, refer to the USDA/GIPSA Excel spreadsheet described below, or call EnviroLogix Technical Support for assistance.



Catalog Number AQ 036 TC

Intended Use

This EnviroLogix QuickComb Kit for bulk grain is designed to extract and detect the presence of certain proteins at the levels typically expressed in genetically modified corn bulk grain. The QuickComb may contain any combination of five to eight of the following QuickStix™:

Protein/Trade Name	Sensitivity	
Cry1A (MON810) / YieldGard Corn Borer*	0.8%	~6 kernels in 800
Cry9C / StarLink	0.125%	1 kernel in 800
CP4 EPSPS / Roundup Ready	0.5%	4 kernels in 800
Cry3Bb / YieldGard Rootworm	0.5%	4 kernels in 800
Cry1F / Herculex I	0.5%	4 kernels in 800
PAT/pat / LibertyLink	0.5%	4 kernels in 800
Cry34 / Herculex RW	0.5%	4 kernels in 800
mCry3A / Agrisure RW	1.0%	8 kernels in 800

* The Cry1A strip will also detect Cry1A.105 and Bt11, but the detection level and quantification calculations are based on MON810.

How the Test Works

In order to detect the proteins expressed by genetically modified bulk grain, the sample must first be extracted to solubilize the protein. All QuickStix included in the QuickComb are specially formulated to detect their analytes in a Common Extraction.

Each QuickStix Strip has an absorbent pad at each end. The protective tape with the arrow indicates the end of the strips to insert into the reaction cup. The sample will travel up the membrane strips and be absorbed into the larger pad at the top of the strip. The portion of the strip between the protective tape and the absorbent pad at the top of the strip is used to view the reactions as described under “Interpreting the Results.” Results are then scanned and interpreted quantitatively with the EnviroLogix QuickScan System. Please avoid bending the comb.

Sample Preparation

1. Collect a composite sample according to USDA/GIPSA instructions found in the reference documents listed in the margin on Page 2.
2. Determine the **average weight** of the grain from the lot to be tested. Count and weigh 100 kernels/seeds, then divide by 100.
3. Calculate the sub-sample weight (g) needed for testing, (number of seeds X **average seed weight**). A sub-sample size of at least 100 grams is required to create enough extract for the test. Weigh out the sub-sample.
4. Calculate water volume needed for sample preparation. The Common Extraction Method calls for a water volume to sample weight ratio of **1.5 to 1**.

Example Calculation using a 400 kernel sub-sample with an average kernel weight of 0.3g.
 $0.3g \times 400 = 120g \times 1.5mL = 180 mL$ water for extraction

USDA References:

- <http://archive.gipsa.usda.gov/reference-library/handbooks/grain-insp/grbook1/bk1.pdf> - USDA Grain Inspection Handbook, Book 1, Grain Sampling.
- <http://archive.gipsa.usda.gov/biotech/sample2.htm> - Guidance document entitled Sampling for the Detection of Biotech Grains.
- <http://archive.gipsa.usda.gov/biotech/sample1.htm> - Practical Application of Sampling for the Detection of Biotech Grains.
- <http://archive.gipsa.usda.gov/biotech/samplingplan1.xls> - This website provides a simple to use Sample Planner (29K Excel Spreadsheet). The planner allows you to enter different assumptions in terms of sample size, number of samples, acceptable quality level and to determine the probability of accepting lots with given concentration levels. It also plots the probabilities in graph form for easy interpretation. Specific data can be saved for documentation and future analyses.

Corn Common Extraction

Grams of Corn x 1.5 = mL of water

For example, 400 kernels with an average seed weight of 0.3 g:

$$(400 \times 0.3) = 120 \text{ g of corn}$$

$$120 \text{ g} \times 1.5 = 180 \text{ mL water}$$

Transfer 20 mL extract to cup:



Either pour...



...or pipette to the 20 mL mark

5. Weigh out the sub-sample and grind using the Auto-Drip setting on the Bunn grinder (or equivalent). The sample should be the consistency of coffee grounds – 60-70% of the sample should pass through a 20-mesh sieve.
6. Place sub-sample into an appropriately sized jar or zip-type plastic bag and add the volume of tap water calculated in Step 4.
7. Cap the jar or “zip” plastic bag and shake vigorously for 30 seconds, then allow sample to settle for another 30 seconds .
8. Transfer 20 mL of the liquid portion from above the settled sample into the sample cup. Pour extract into cup to the 20 mL line, or use a fresh pipette from the kit to transfer extract until the 20 mL line is reached. Important: Avoid transferring particles as much as possible, and after transfer, allow the liquid in the sample cup to settle for 30 seconds so that any particles will settle at the bottom of the cup.
9. To prevent cross-contamination, thoroughly clean blender parts and jars to remove dust and residue prior to preparation of each sample, and use a new sample cup for each. If pipetting, always use a new pipette for each sample.

How to Run the QuickComb Test

1. Remove a QuickComb from the foil bag and return unused combs to original container (avoid handling loose comb end). Use the blank space on the back of the comb to label sample, if desired. Place the comb of strips into the sample cup, being sure to insert the end indicated by the arrows on the protective tape.
2. After inserting the comb into the extract, liquid will travel up the membrane strips toward the absorbent pads at the top of the strips. Soon after complete wetting of the membranes, lines will appear on the membranes approximately 1/4 inch below the top absorbent pad. These are the Control Lines.
3. Allow the strips to develop for a full 5 minutes before making final assay interpretations. Remove the QuickComb from the cup; cut off and discard the bottom section of each strip covered by the arrow tape; and place QuickComb in the QuickScan Reader - combs must be read immediately after cutting, while still wet.

Interpreting the Results

Development of the Control Lines within 5 minutes indicates that the strips have functioned properly. Any strip that does not develop a Control Line should be discarded and the sample re-tested using another strip.

Results are scanned and interpreted quantitatively with the QuickScan System. Place QuickComb into the carrier, slide in, and press “Read Test” on the screen. QuickScan will return a result as “% GMO” or “<LOQ” (less than the Limit of Quantification) for each strip on the comb. Please consult the QuickScan User Manual for details.

Kit Storage

This QuickComb Kit should be stored at room temperature, or refrigerated for longer shelf life. Please note the shelf life on the kit box for each storage temperature. The kit may be used in field applications; however, prolonged exposure to high temperatures may adversely affect the test results. Important: do not open the foil bag until ready to use the combs. Allow container to come to room temperature before opening to prevent condensation.



(outlined to demonstrate cup size and markings)

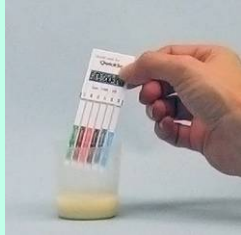

After 30 seconds, add QuickComb to cup



Precautions and Notes

- The QuickComb is designed to give quantitative results using the QuickScan System and is not intended to be visually interpreted.
- As with all tests, it is recommended that results be confirmed by an alternate method when necessary.
- The assay has been optimized to be used with the protocol provided in the kit. Deviation from this protocol may invalidate the results of the test.
- The results generated through the proper use of this kit reflect the condition of the working sample directly tested. Extrapolation as to the condition of the originating lot, from which the working sample was derived, should be based on sound sampling procedures and statistical calculations which address random sampling effects, non-random seed lot sampling effects and assay system uncertainty. A negative result obtained when properly testing the working sample does not necessarily mean the originating lot is entirely negative for the analyte or protein in question.
- Protect all components from hot or cold extremes of temperature when not in use. Do not leave in direct sunlight or in a vehicle.

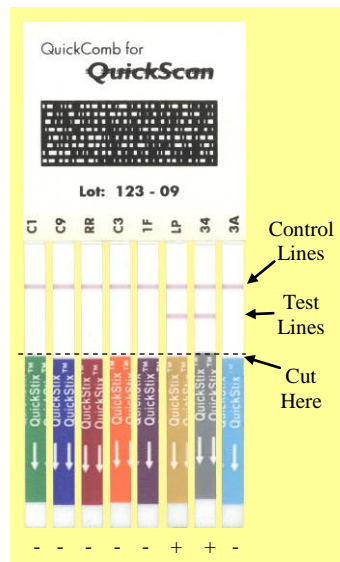



**For Technical Support
Contact Us At:**

EnviroLogix
500 Riverside Industrial
Parkway
Portland, ME 04103-1486
USA

Tel: (207) 797-0300
Toll Free: 866-408-4597
Fax: (207) 797-7533

e-mail:
info@envirologix.com

website:
www.envirologix.com



LIMITED WARRANTY

EnviroLogix Inc. (“EnviroLogix”) warrants the products sold hereunder (“the Products”) against defects in materials and workmanship when used in accordance with the applicable instructions for a period not to extend beyond a product’s printed expiration date. If the Products do not conform to this Limited Warranty and the customer notifies EnviroLogix in writing of such defects during the warranty period, including an offer by the customer to return the Products to EnviroLogix for evaluation, EnviroLogix will repair or replace, at its option, any product or part thereof that proves defective in materials or workmanship within the warranty period.

NEITHER ENVIROLOGIX NOR MONSANTO MAKES ANY OTHER WARRANTIES, EXPRESS OR IMPLIED, INCLUDING BUT NOT LIMITED TO ANY IMPLIED WARRANTIES OF MERCHANTABILITY OR FITNESS FOR A PARTICULAR PURPOSE. The warranty provided herein and the data, specifications and descriptions of EnviroLogix products appearing in EnviroLogix published catalogues and product literatures are EnviroLogix’ sole representations concerning the Products and warranty. No other statements or representations, written or oral, by EnviroLogix’ employees, agents or representatives, except written statements signed by a duly authorized officer of EnviroLogix Inc., are authorized; they should not be relied upon by the customer and are not a part of the contract of sale or of this warranty.

EnviroLogix does not warrant against damages or defects arising in shipping or handling, or out of accident or improper or abnormal use of the Products; against defects in products or components not manufactured by EnviroLogix, or against damages resulting from such non-EnviroLogix made products or components. EnviroLogix passes on to customer the warranty it received (if any) from the maker thereof of such non-EnviroLogix made products or components. This warranty also does not apply to Products to which changes or modifications have been made or attempted by persons other than pursuant to written authorization by EnviroLogix.

THIS WARRANTY IS EXCLUSIVE. The sole and exclusive obligation of EnviroLogix shall be to repair or replace the defective Products in the manner and for the period provided above. EnviroLogix shall not have any other obligation with respect to the Products or any part thereof, whether based on contract, tort, strict liability or otherwise. Under no circumstances, whether based on this Limited Warranty or otherwise, shall EnviroLogix be liable for incidental, special, or consequential damages.

This Limited Warranty states the entire obligation of EnviroLogix with respect to the Products. If any part of this Limited Warranty is determined to be void or illegal, the remainder shall remain in full force and effect.

License

EnviroLogix has developed some tests in this kit using proprietary reagents as well as reagents licensed from Monsanto Company.

Roundup Ready and YieldGard are registered trademarks of Monsanto Technology, LLC

Agrisure is a registered trademark of Syngenta Group Company

LibertyLink is a trademark of Bayer

Herculex is a trademark of Dow AgroSciences LLC

StarLink is a trademark of Aventis CropScience

EnviroLogix, the EnviroLogix logo, QuickComb, QuickStix, Common Extraction, and QuickScan are trademarks of EnviroLogix Inc.

© EnviroLogix 2011